

MBT124 Turning Bars - Metal BT124 Turning Bars - Wood

Parts List			
DESCRIPTION	MBT124	BT124	PART NUMBER
57" TURNING BAR	3	3	402994
7'-0" ALUMINUM COLUMN - TB 1H	1	0	404571
8'-0" ALUMINUM COLUMN - TB 2H	1	0	404573
9'-0" METAL COLUMN - TB 2H	1	0	404577
9'-0" ALUMINUM COLUMN - TB 1H	1	0	404575
7'-0" COLUMN LAM	0	1	Z01-004
8'-0" COLUMN LAM	0	1	Z01-007
9'-0" COLUMN LAM	0	2	Z01-008
COLUMN CONNECTOR - METAL	4	0	E013
COLUMN CONNECTOR - WOOD	0	4	D010
END CAP	1	1	G010
HOLE PLUG - M	3	0	M005G
COLUMN END FITTING - METAL	1	0	M600
COLUMN END FITTING - WOOD	0	1	Z600
#10 x 2" WOOD SCREW	0	3	815507
----- HARDWARE COMPLETE -----	4	0	E013HW
1/4" x 15/32" DRIVE RIVET	2	0	805303
#10 x 1/2" SHEET METAL SCREW	3	0	810062
----- HARDWARE COMPLETE -----	3	0	402814
----- HARDWARE COMPLETE -----	0	3	402815
PIPE MOUNT BODY - 1"	2	2	404153
PIPE MOUNT CAP - 1"	2	2	404154
1/2" THREADED INSERT	6	0	M000
EAGLE FASTENER	0	2	G000
3/8" x 2" SOCKET HEAD CAP SCREW SS	2	2	816087
1/2" x 1 3/4" HEX HEAD BOLT	2	0	801206
1/2" x 2 1/2" HEX HEAD BOLT	0	2	801225
1/2" INTERNAL TOOTH LOCKWASHER	2	2	817201
1/2" LOCKWASHER	6	0	817342

Unless Otherwise Specified, All Units of Measure are Each

Items listed below Hardware Complete line are included with Hardware Complete Number

Warning: During Installation, Hardware And Small Parts Are Choking Hazards For Young Children. Store Unused Parts Appropriately Until Assembly Is Completed. Once Assembly Is Completed, Remove Any Unused Parts From The Play Environment And Dispose/Save Them In A Secure Location. Any bolt end protruding more than two full threads beyond the face of the nut causes risk of clothing entanglement.

Promptly cut-off flush, file smooth, and treat to prevent corrosion.

Note: Peen Tee-Nuts and Flatwashers to match radius of pipe after assembly is complete.

Note: Loctite (supplied by others) should be used on any non-patch hardware.

MBT124 Turning Bars - Metal BT124 Turning Bars - Wood

INSTALLATION INSTRUCTIONS:

1. Refer to your structure design and determine the location and orientation of your Turning Bars. Locate and dig footing holes. Refer to Installation Prolog for information for information about installing Typical Column Connectors, Typical Concrete Footings, and Typical Hole Plug Installation.
2. Attach Pipe Mount Body to Column using 1/2" Threaded Insert, 1/2" Lock Washer, and 1/2" x 1 3/4" Hex Head Bolt. If installing the wood version, use Eagle Fastener, 1/2" Lock Washer, and 1/2" x 2 1/2" Hex Head Bolt. See Detail 132. Refer to Installation Prolog for information for information about Threaded Inserts or Eagle Fasteners.
3. Attach Turning Bar to Pipe Mount Body using 3/8" x 2" Socket Head Cap Screw and Pipe Mount Cap. See Detail 133.
4. Install proper Hole Plugs in all open holes in Columns.
5. Plumb and level the entire assembly and tighten all fasteners.
6. After entire unit is assembled, pour concrete footings within 4" to the top and taper away from post for water drainage. Allow to cure at least 48 hours before use. Temporary bracing may be required until concrete cures.
7. When the structure is finished and satisfactory, eliminate sharp points and sharp edges (burring) on installed hardware like bolts, nuts, etc. Install resilient surfacing material within the use zone of play structure in accordance with ASTM specifications F1292 (or other standards as applicable) appropriate for the fall height of each structure. Refer to all applicable safety guidelines for more information.

MAINTENANCE PROCEDURE:

Periodically check hardware for tightness, and tighten as necessary. Always check all parts for breakage or wear, and immediately put equipment out of service until any faulty parts found are repaired or replaced. Also Check all metal parts for rust, paint loss and touch-up if necessary with paint. Check for welded areas and verify integrity. Check periodically resilient surfacing for appropriate depth and remove extraneous materials that could cause injury, infection, or disease. Maintain detailed installation, inspection, maintenance, and repair records for each public-use playground equipment.

MBT124 Turning Bars - Metal BT124 Turning Bars - Wood

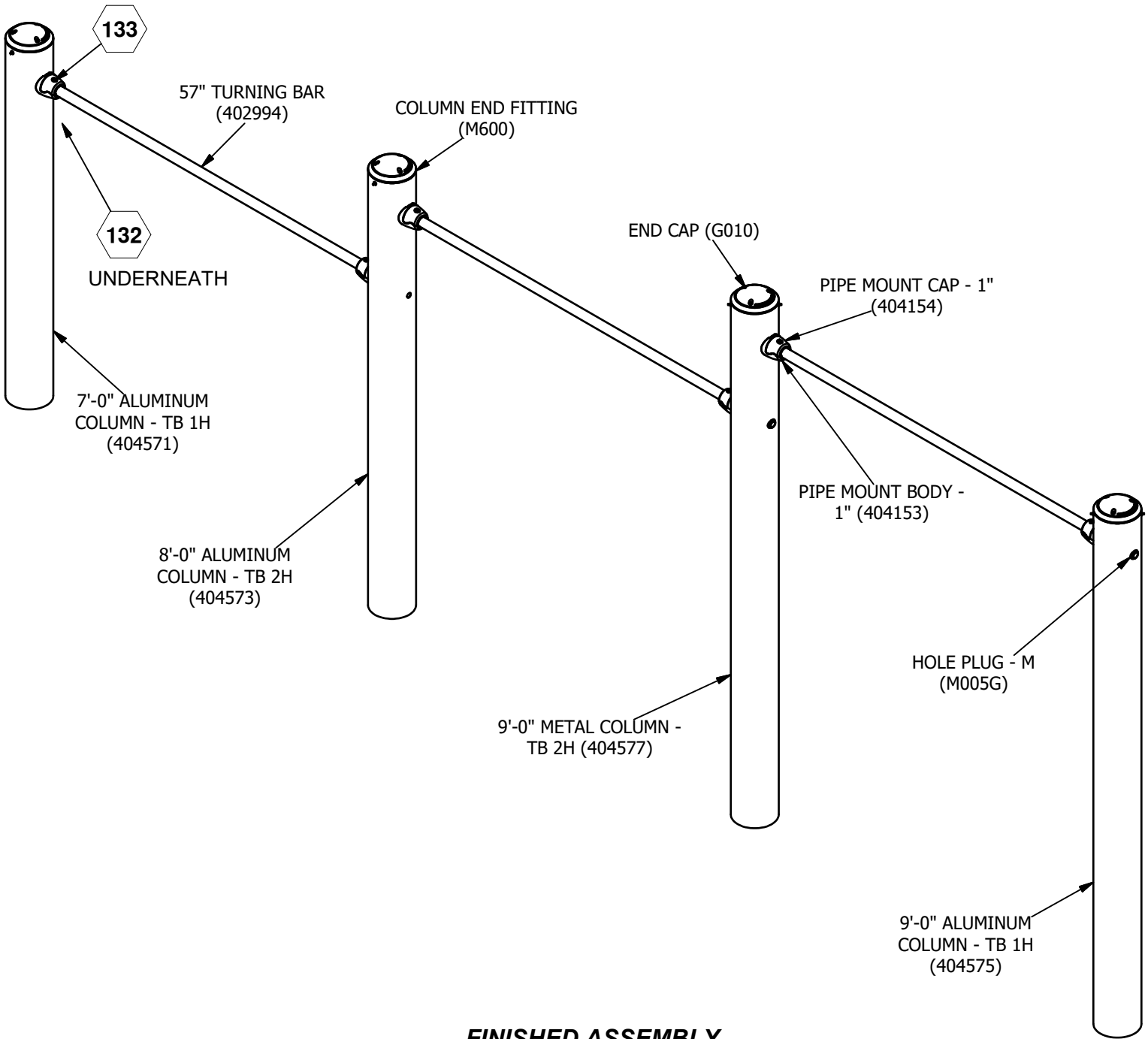

 = INSTALLATION DETAIL

MBT124 Turning Bars - Metal BT124 Turning Bars - Wood

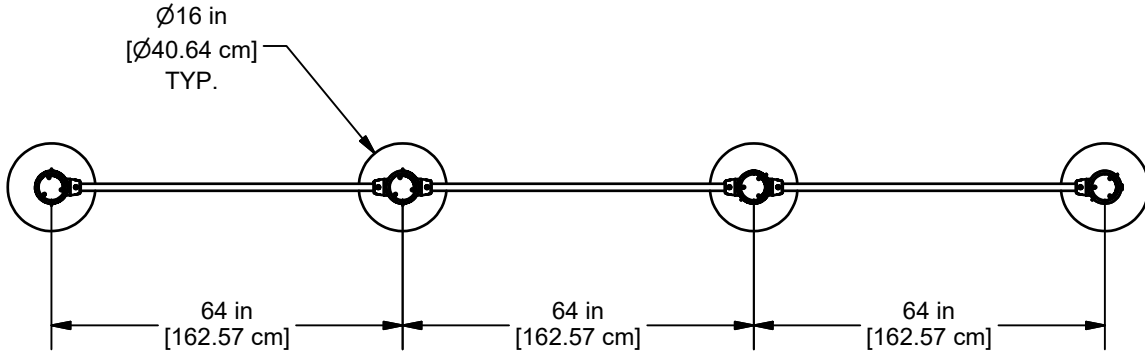

PLAN VIEW

CONCRETE REQUIRED

0.56 CUBIC YARDS
0.43 [CUBIC METERS]

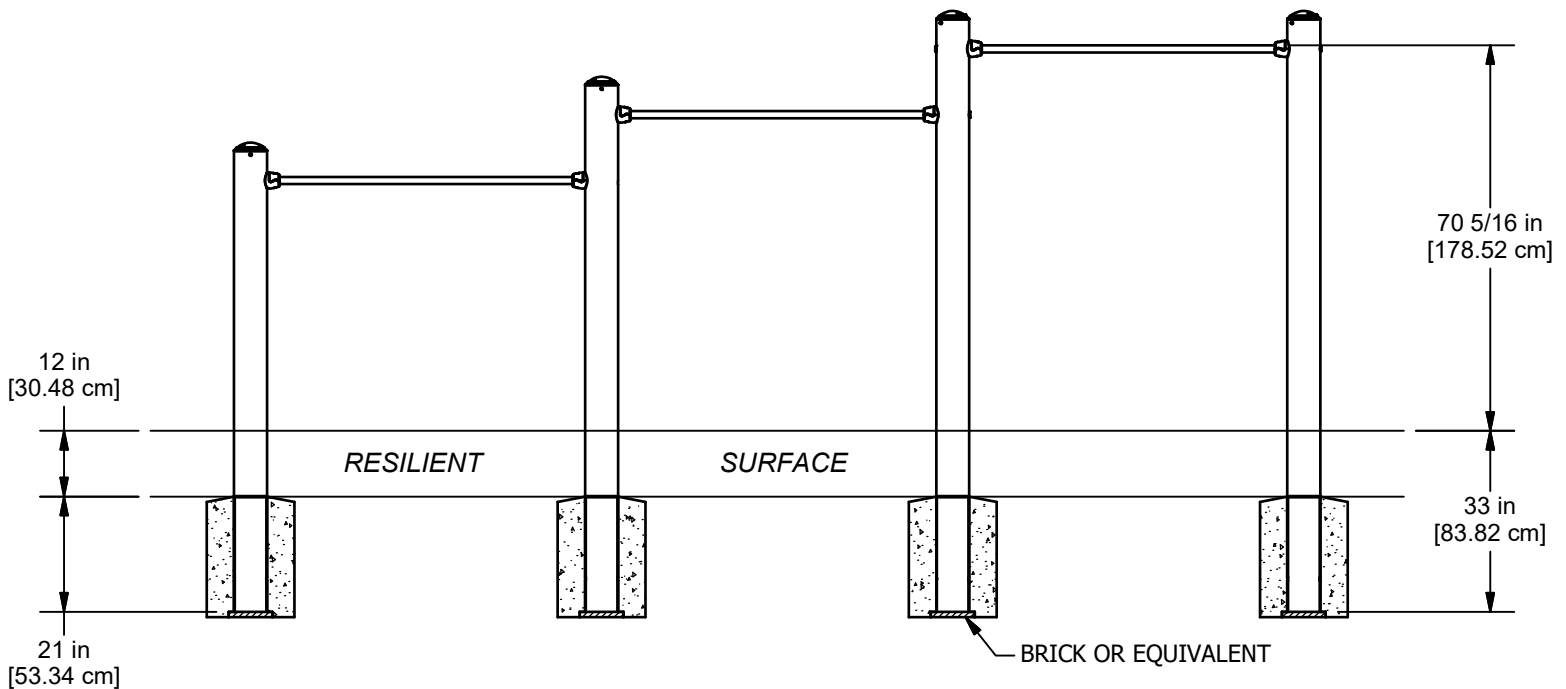

ELEVATION VIEW

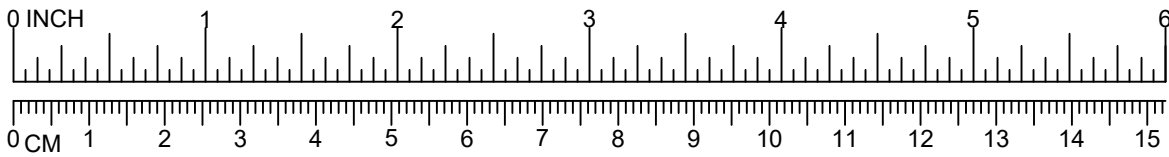

MBT124 Turning Bars - Metal BT124 Turning Bars - Wood

NOTE: REFER TO THE INSTALLATION PROLOG FOR TYPICAL THREADED INSERT AND EAGLE FASTENER INSTALLATION.

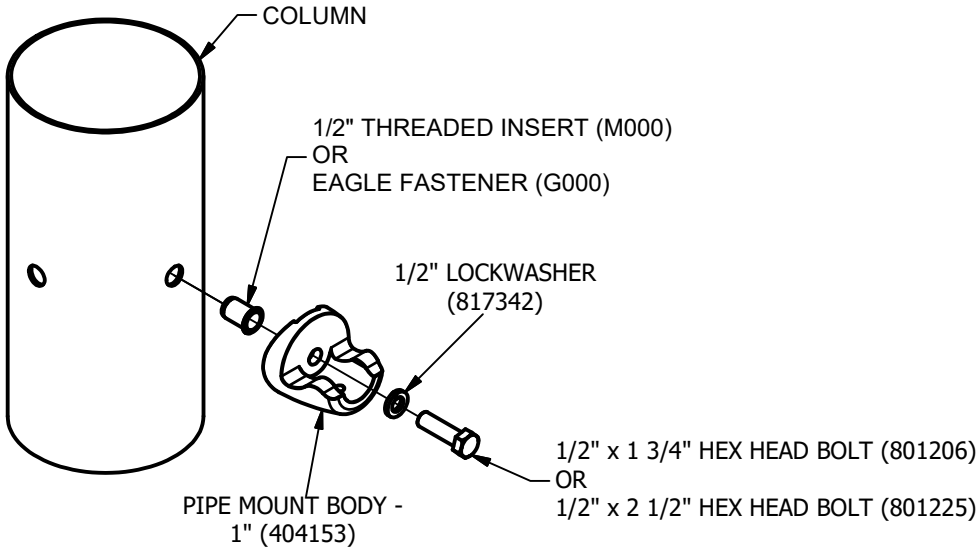

132

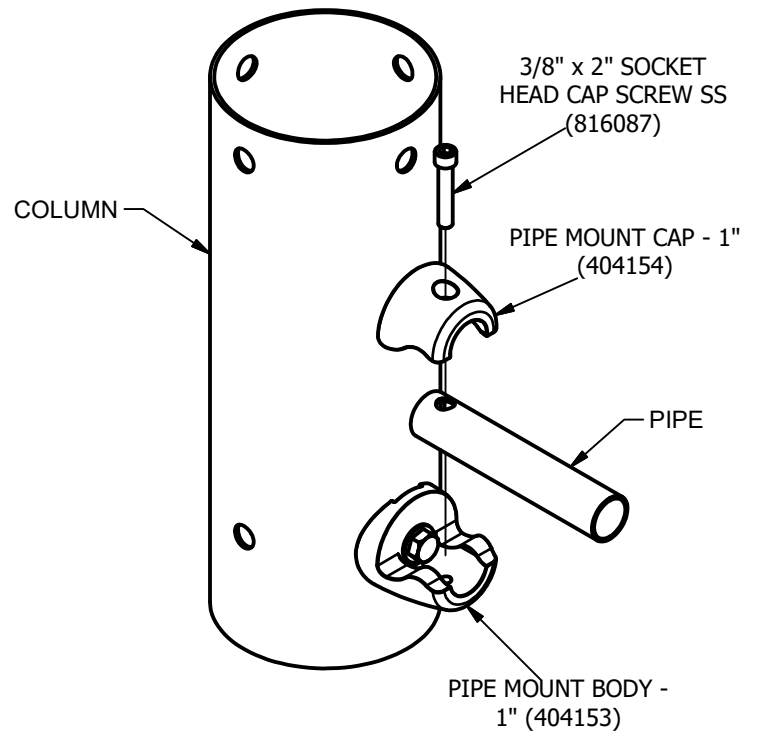

133