

Sport Board Spring Rider

MBT-427
Installation Instructions

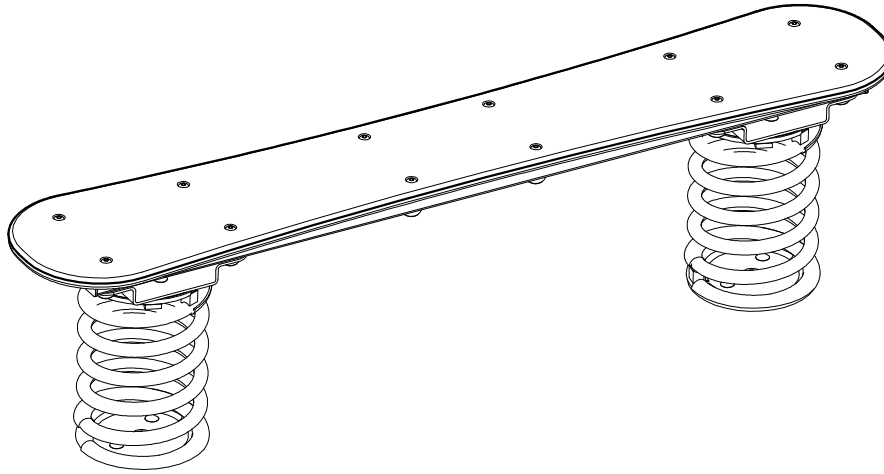

DET.	QTY.	PART#	DESCRIPTION	ICON (NOT TO SCALE)
A	1	2327	Sport Board	
B	2	402330	300mm Mod Spring Assy.	
C	2	L638S_	Support, Sport Board	
	1	D993_	Connector, Sport Board	
D	4	H379	Cap, Rect. Tube, 1" X 2" 10-14 GA	
E	12	G030GY	Do-Nut Base (No Boss) 10mm	
F	12	G032GY	Do-Nut Cap 10mm	
G	12	811056	Cap Screw, 3/8 x 2-1/4" BTN HD SS	
H	12	804353	Nut Hex 3/8-16 2-Way Locknut NC PLTD	
I	24	817460	Washer 3/8" SS (.391ID x .62 OD) Flat	
J	4	817424	Washer Fender 3/8 x 1-1/4" OD SS	
		E402D	Decal Package 5-12	

1. Refer to your site design layout for location of the Sport Board Spring Rider.
2. **Layout footings and dig holes** as shown.
3. **Assemble Footing and Spring** with Hardware provide in box.

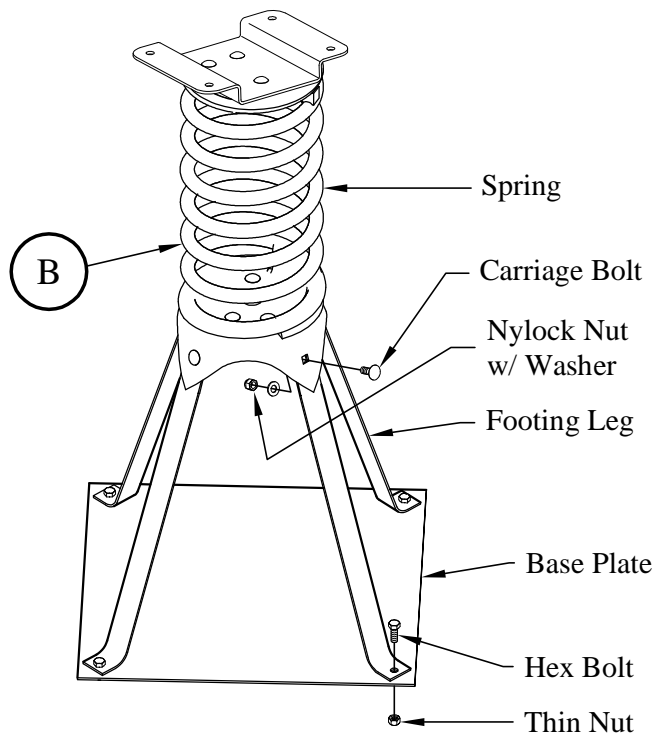
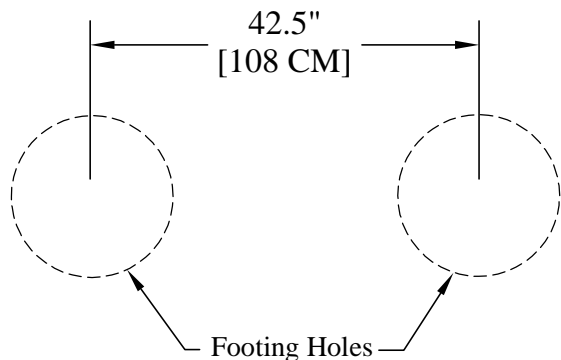

Assemble Footing and Spring

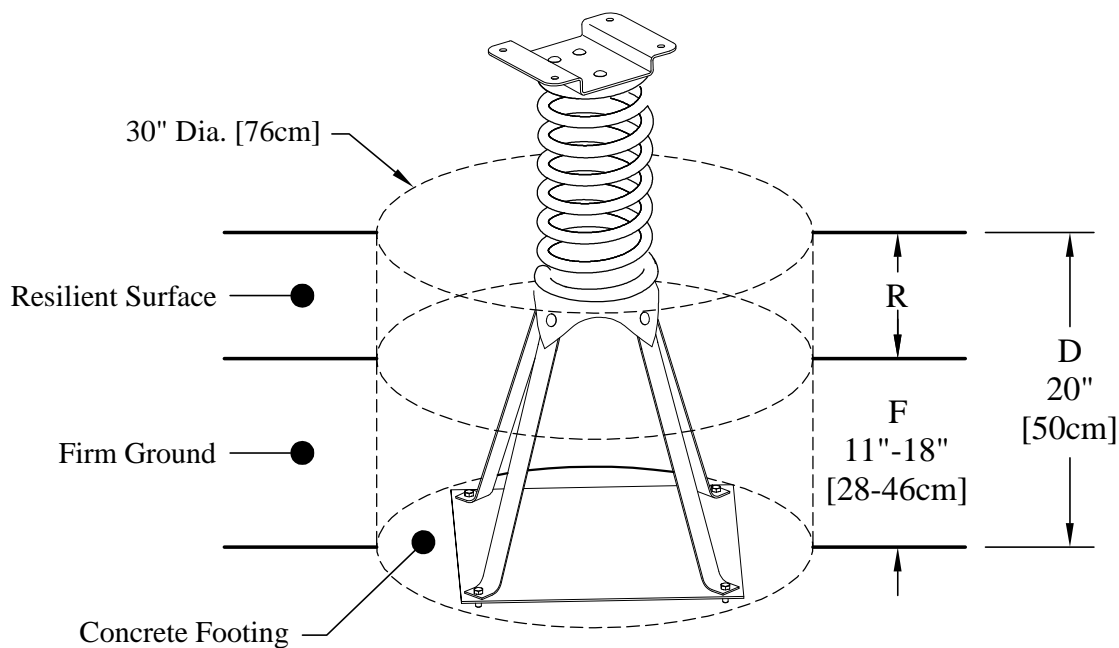

To find footing depth use this formula $D - R = F$

Approximate Concrete Volume 4.5 Cubic Feet or 0.13 cubic meters.

Footing Hole

4. **Attach Sport Board (A)** to Supports (C) using hardware (G)(I)(J)(E)(H)(F) as shown. Insert End Cap (D) into both ends of Supports (C) and set with Rubber Mallet.

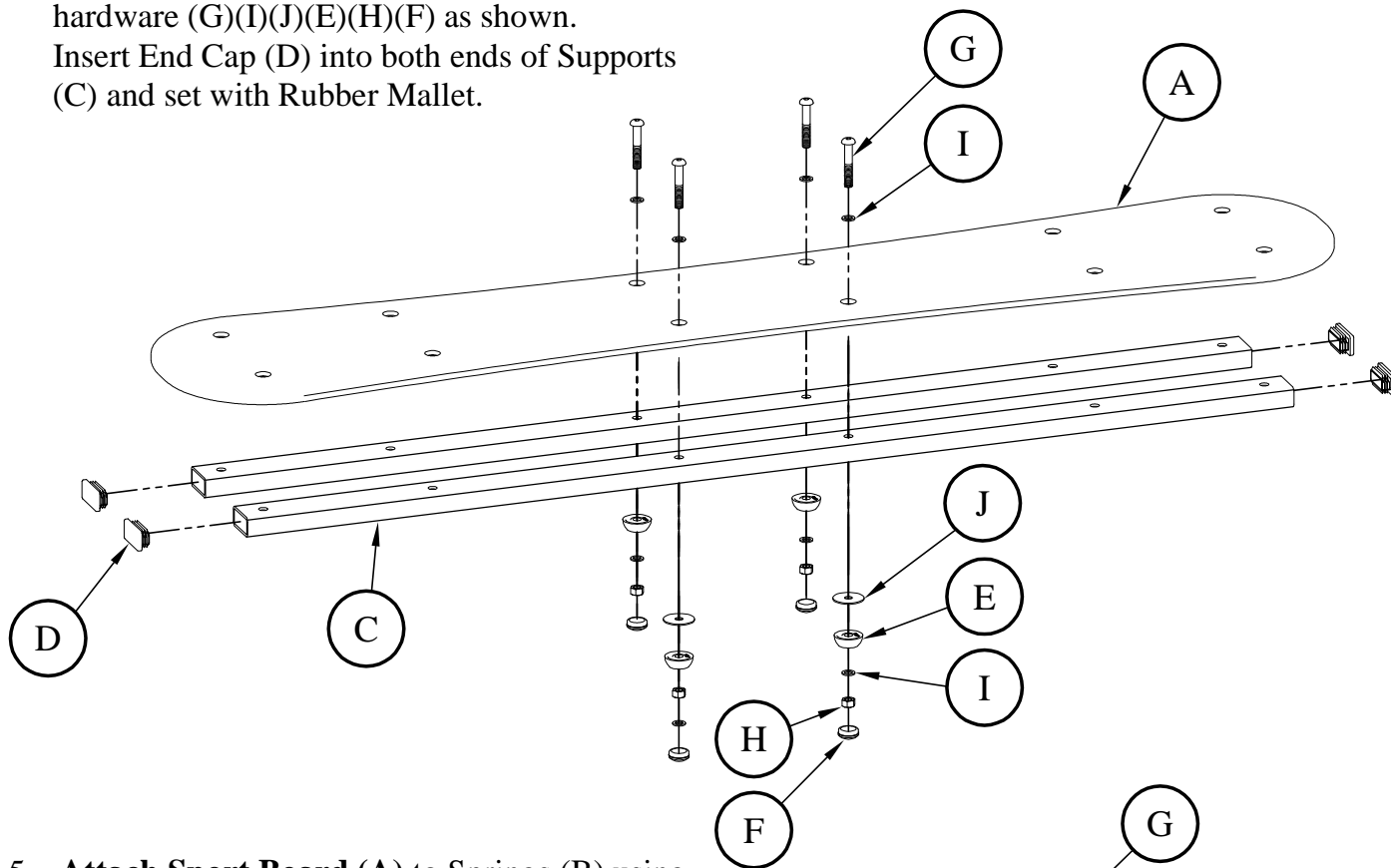

5. **Attach Sport Board (A)** to Springs (B) using hardware (G)(I)(E)(H)(F) as shown.

