

BT530 PLAYPOD MAZE CURVED

Parts List		
DESCRIPTION	QTY	PART NUMBER
PLAYPOD w/1.38" HOLE	11	G441
3-RAIL BRACKET	2	G519
12' COLUMN, G-LAM	4	Z012
30" PLAYPOD HANGER ASS'Y	2	401994
18" PLAYPOD HANGER ASS'Y	5	402001
24" PLAYPOD HANGER ASS'Y	4	402039
157" CURVED OUTER PLAYPOD RAIL	2	G485
157" CURVED INNER PLAYPOD RAIL	1	G484
HARDWARE COMPLETE	1	405562
U-NUT HANGER	11	0104
EAGLE FASTENER	8	G000
HOLE PLUG	136	G005G
END CAP	4	G010
12MM DO-NUT BASE	20	G034
12MM DO-NUT CAP	20	G036
3/8" CHAIN (2 LINKS)	11	H443
COLUMN END FITTING - WOOD	4	Z600
10" PIPE	4	401991
#10 x 2" WOOD SCREW	12	815507
3/8" x 3/4" S.S. SHOULDER SCREW	11	802720
3/8" x 1" P.B.H.C.S. w/PATCH	33	812050
3/8" x 4" P.B.H.C.S. w/PATCH	22	812082
3/8" FLAT WASHER	77	817410
1/2" x 1 3/4" HEX HEAD BOLT	8	801206
1/2" x 2 3/4" HEX HEAD BOLT	6	801210
1/2" LOCKNUT	6	804355

Unless Otherwise Specified, All Units of Measure are Each

Items listed below Hardware Complete line are included with Hardware Complete Number

Warning: During Installation, Hardware And Small Parts Are Choking Hazards For Young Children. Store Unused Parts Appropriately Until Assembly Is Completed. Once Assembly Is Completed, Remove Any Unused Parts From The Play Environment And Dispose/Save Them In A Secure Location. Any bolt end protruding more than two full threads beyond the face of the nut causes risk of clothing entanglement.

Promptly cut-off flush, file smooth, and treat to prevent corrosion.

Note: Peen Tee-Nuts and Flatwashers to match radius of pipe after assembly is complete.

Note: Loctite (supplied by others) should be used on any non-patch hardware.

SPECIFICATIONS:

Playpod w/1.38" Hole: Shall be fabricated from linear low-density polyethylene (LLDPE) with UV-stabilized colorant and an anti-static compound additive. The tensile strength of this material is 2500 PSI, as defined in ASTM D638. The typical wall thickness will be .250" (1/4"). ASTM D-1248, type 2, class A and Federal specification LP-390c, type 1, class M, grade 2, category 3; Density (ASTM D-1505); Brittleness Temperature (ASTM D-790); Heat Distortion (ASTM-648); Low Temperature Impact (ARM-STD).

3-Rail Bracket: Shall be an all welded construction fabricated from 1 1/2" x 3" rectangular tubing, 3/16" x 2 1/4" steel tab, and 3/16" pickled and oiled hot rolled steel upright tab. The 3-Rail Bracket shall be coated after fabrication with a custom formula of TGIC polyester powder coating in conformance with the specifications outlined herein.

BT530 PLAYPOD MAZE CURVED

12' Column: Shall be fabricated by using glue-laminated Scots Pine, with an outside diameter of 6". 6" from each end, and at every 12" increment, there are four 1 1/8" holes drilled 90° apart. The columns are cut in lengths ranging from two feet though 12 feet in one-foot increments. In the field, an aluminum/zinc (Eagle) fastener may be installed into the holes wherever another component is attached to the column. Polypropylene (PP) Hole Plugs may be installed into all holes that are not used for other component attachments, and a polypropylene (PP) column end fitting and color scheme appropriate plastic end cap are attached to the top end of the column.

30", 18", and 24" Playpod Hanger Ass'y: Shall be an welded construction fabricated with 1" schedule 40 pipe, 1 5/16" steel round bar ASTM A-36, 3/16" hot rolled steel flange, and 14 gauge x 1.5" galvanized steel pipe cap with a 5/0 welded machine chain connected to the flange by 3/8" x 4 1/16" u-bolt, 3/8" hex nut, and 3/8" lock nut. The welded parts shall be coated after fabrication with a custom formula of TGIC polyester powder coating in conformance with the specifications outlined herein.

157" Outer and Inner Playpod Rail: Shall be an all welded construction fabricated from 1 1/2" x 3" rectangular tubing and a 1/8" x 1 1/2" hot rolled flat black steel tab. The 157" Outer and Inner Playpod Rail shall be coated after fabrication with a custom formula of TGIC polyester powder coating in conformance with the specifications outlined herein.

Hardware: All nuts, bolts, screws, inserts, and lock washers used in the assembly of all play equipment, shall be stainless steel, yellow dichromate plated steel, blue-coated plated steel, mechanically galvanized or powder coated/yellow dichromate plated steel. All primary fasteners shall be 300 series stainless steel. Fasteners with yellow dichromate treatment have an electro deposited, 99.9% pure zinc substrate applied from a specially formulated solution sealed with a yellow dichromate top coat designed to work in conjunction with the zinc plating. Yellow dichromate has a 320% longer life to white corrosion and 275% longer to red corrosion than does hot-dip galvanizing. Galvanizing coverage shall demonstrate the ability to exceed 1000 hours salt spray corrosion exposure in accordance with ASTM B-117. Internal surface zinc rich 81% minimum zinc dust content in organic resin, as per ASTM F-1234, Section 5.2.4, Type D.

U-Nut Hanger: Shall be fabricated from 1/2" diameter 304 stainless steel round bar

Eagle Fastener: (U.S. Pat. No. 3,814,416) The Eagle Fastener is a proprietary expansion fastener that is die-cast from zinc/aluminum alloy (ZA3) and is used to secure columns. The Eagle Fastener has been designed to securely attach a variety of components to a wood column by expanding within a column's Eagle Hole using fins and teeth to prevent rotation and extraction from the column. The Eagle Fastener contains a 1/2-13 nut having a nylon locking ring to prevent loosening after assembly.

Hole Plug: Hole Plugs for wood columns are injection-molded of high-impact polypropylene (PP) plastic, with colorant and UV inhibitor. The Hole Plugs are used to fill unused holes in columns following field assembly. When installed, the Hole Plug for Wood Columns expands to secure the Hole Plug into the hole using teeth and fins similar to those on the Eagle Fastener.

End Cap: Shall be fabricated from injection-molded from high-impact polypropylene (PP) with colorant and UV inhibitor. The caps are used at the top end of Standard Columns and attach in the field to the Column End Fitting using #10 stainless steel screws.

Do-Nut: Do-Nuts are bolt covers that are injection-molded from Nylon (PA6) in two parts, a base and cap, which are always used together. Two sizes of Do-Nuts are available to cover either 1/2 inch bolts or 3/8 inch bolts. Do-Nuts designed to cover 1/2" bolts have a maximum diameter of 1 7/8 inches while Do-Nuts designed to cover 3/8 inch bolts have a maximum diameter of 1 3/8 inches. Do-Nuts caps are self-locking when driven into the base after final bolt tightening. Do-Nuts provide protection against bolt head, bolt end, and nut protrusions to meet the protrusion criteria established by applicable ASTM and CSA standards and CPSC guidelines.

3/8" Chain (2 Links): Shall be fabricated from 3/8" proof coil chain. Working load limit: 2650 lbs. Links per foot: 8.8. Material: low carbon steel w/galvanized finish.

Column End Fitting: Shall be fabricated from injection-molded of high-impact polypropylene (PP) plastic, with colorant and UV inhibitor.

10" Pipe: Shall be fabricated from 1.029" x .072" (15 gauge) galvanized pipe.

INSTALLATION INSTRUCTIONS:

1. Dig footing holes as shown in Elevation and Plain Views. See Top View for dimensions and notes regarding surfacing, etc. NOTE: *Due to extremes in weather and soil conditions, hole sizes may have to be increased to meet local conditions.*
2. Attach Column End Fitting and End Cap to 12' Column using #10 x 2" wood screw. See Detail 032.
3. Place 12' Columns in correct holes as shown in Plan View. **NOTE: Insert 10" pipe into bottom hole of Column. See Detail 039.**

BT530 PLAYPOD MAZE CURVED

4. Attach 3-Rail Bracket to 12' Columns using Eagle Fastener, 12mm Do-Nut Base, 1/2" x 1 3/4" Hex Head Bolt, and 12mm Do-Nut Cap. See Detail 188.
5. Attach 157" Outer and Inner Playpod Rail to the 3-Rail Bracket using 12mm Do-Nut Cap, 1/2" x 2 3/4" Hex Head Bolt, 12mm Do-Nut Base, and 1/2" Lock Nut. See Detail 189.
6. Slide Playpod w/1.38" Hole over the Playpod Hanger Ass'y. Locate 3/8" Chain (2 Links) and attach to Playpod Hanger Ass'y using 3/8" x 3/4" S.S. Shoulder Screw. See Detail 004.
7. Slide U-Nut Hanger through top link of 3/8" Chain (2 Links). Attach assembled Playpod Hanger Ass'y to 157" Outer and Inner Playpod Rail using 3/8" x 4" P.B.H.C.S w/Patch and 3/8" Flat Washer. See Detail 005.
8. Raise each Playpod to expose the top nuts on the U-Bolt at the bottom of the Playpod Hanger Ass'y, adjust the U-Bolt Nuts to obtain 6" max. range motion in any direction. Fasten Playpods to Playpod Hangers using 3/8" x 1" P.B.H.C.S. w/Patch and 3/8" Flat Washer. See Detail 007.
9. Plug all unused holes in columns with Hole Plugs.
10. Plumb and level the entire assembly and tighten all fasteners.

IMPORTANT! Avoid creating any gaps between the components which fall between 3-1/2" and 9". It has been shown that such gaps create entrapment points which can trap a child and cause injury.

11. After entire unit is assembled pour concrete footings within 4" to the top and taper away from post for water drainage. Allow to cure at least 48 hours before use. Temporary bracing may be required until concrete cures.
12. When the structure is finished and satisfactory, eliminate sharp points and sharp edges (burring) on installed hardware like bolts, nuts, etc. Install resilient surfacing material within the use zone of play structure in accordance with ASTM specifications F1292 appropriate for the fall height of each structure. Refer to the safety guidelines.

MAINTENANCE PROCEDURE:

Periodically check hardware for tightness, and tighten as necessary. Always check all parts for breakage or wear, and immediately put equipment out of service until any faulty parts found are repaired or replaced. Also Check all metal parts for rust, paint loss and touch-up if necessary with paint. Check for welded areas and verify integrity. Check periodically resilient surfacing for appropriate depth and remove extraneous materials that could cause injury, infection, or disease. Maintain detailed installation, inspection, maintenance, and repair records for each public-use playground equipment.

BT530 PLAYPOD MAZE CURVED

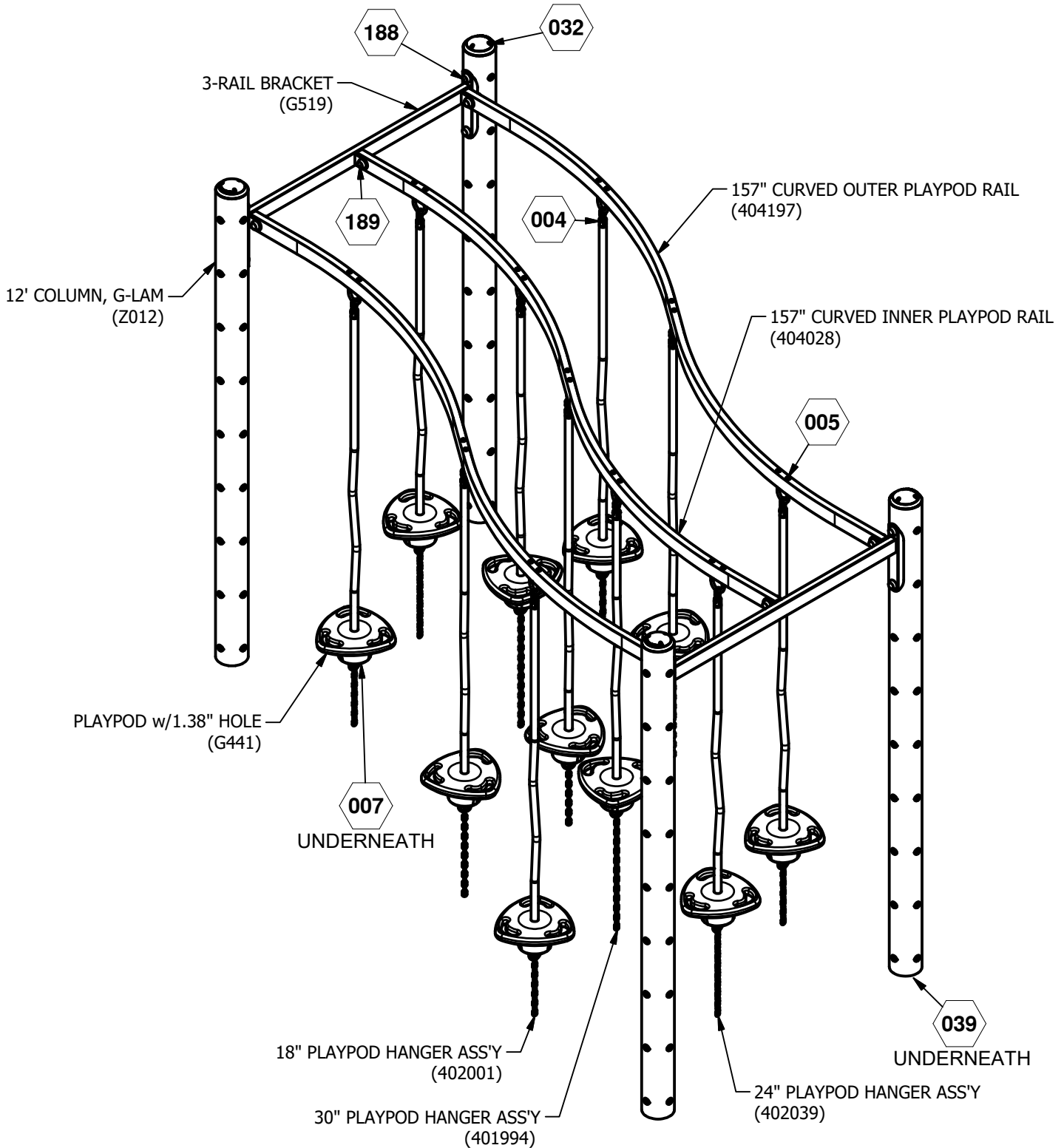

FINISHED ASSEMBLY

 = INSTALLATION DETAIL

Issued/Revised: 5/29/2019

COMPONENTS SHOWN IN
HIDDEN LINES ARE SOLD SEPARATELY
SHEET 4 OF 7

BT530 PLAYPOD MAZE CURVED

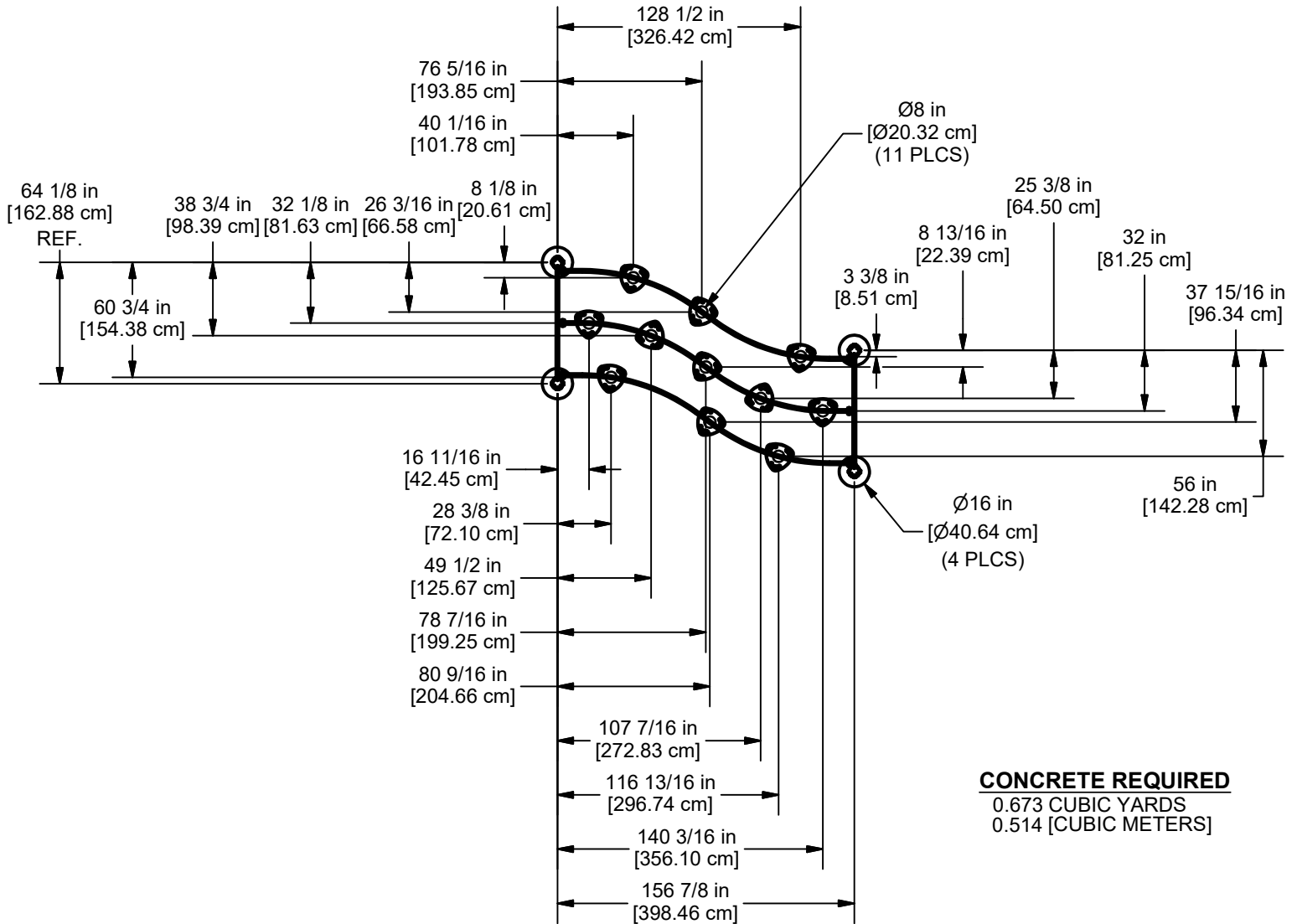

FINISHED ASSEMBLY

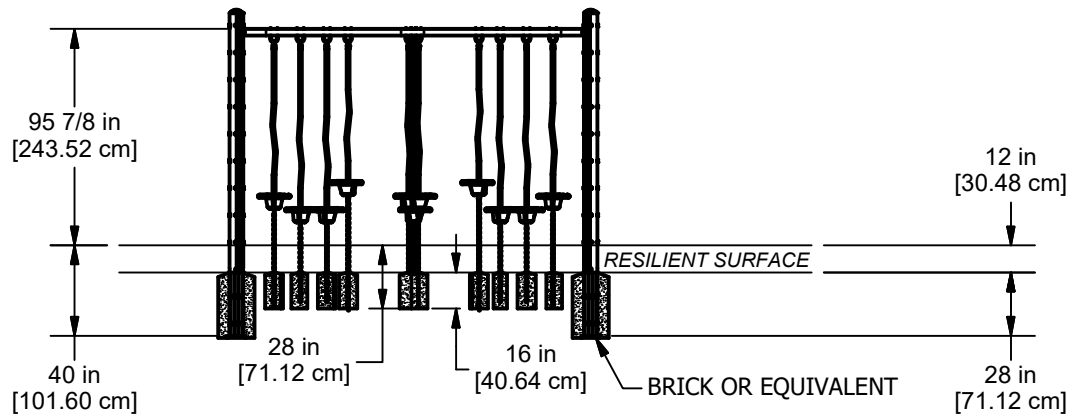

ELEVATION VIEW

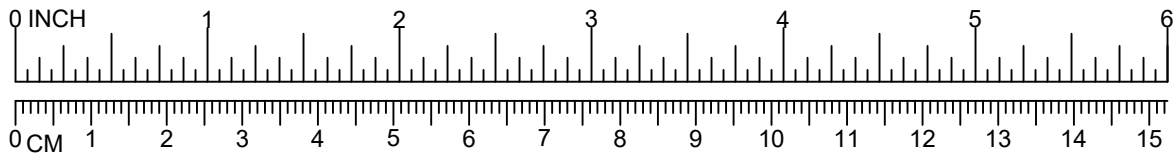

BT530 PLAYPOD MAZE CURVED

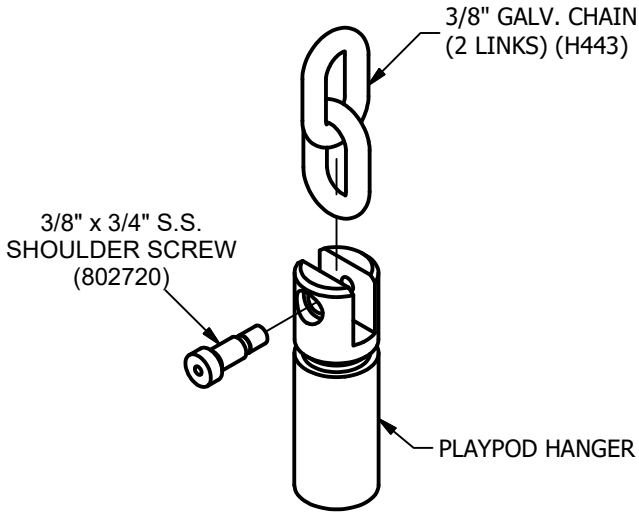

004

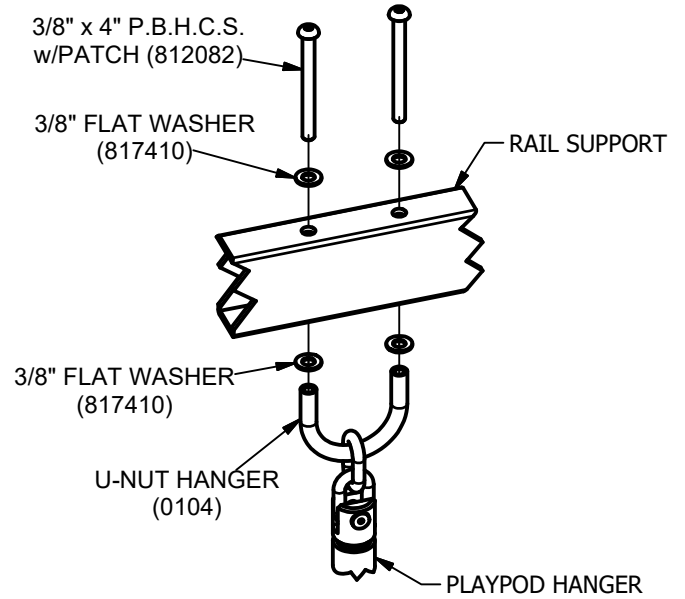

005

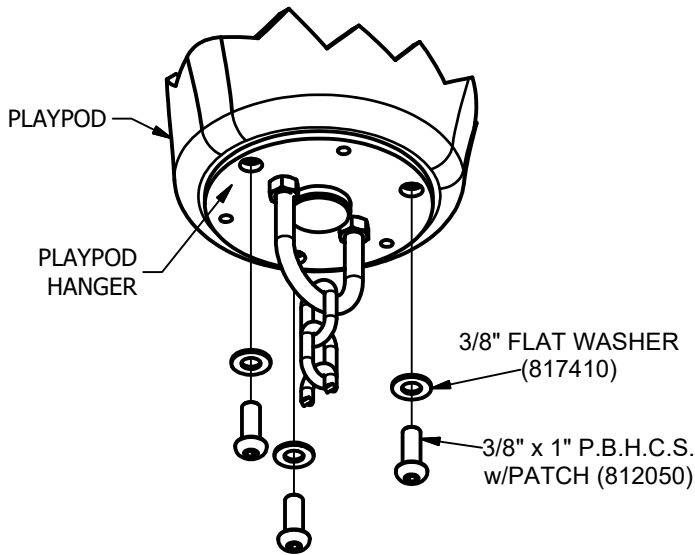

007

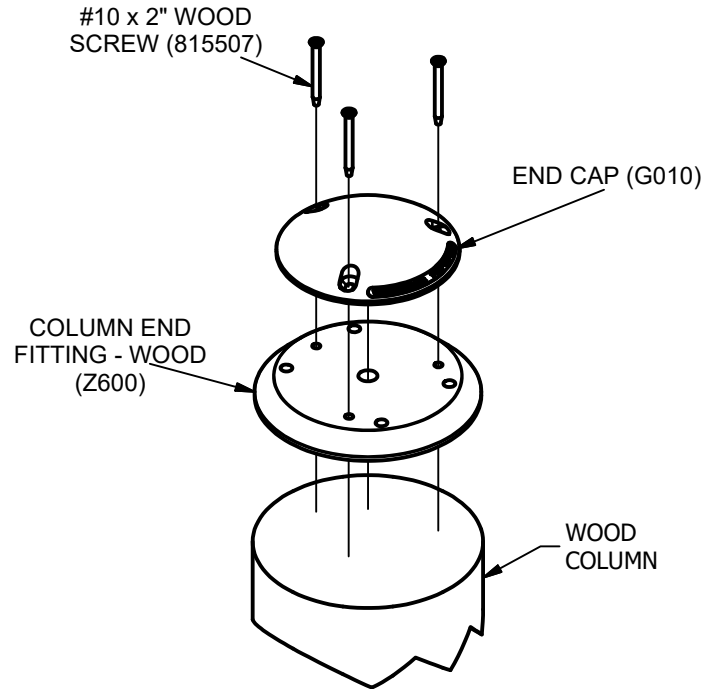

032

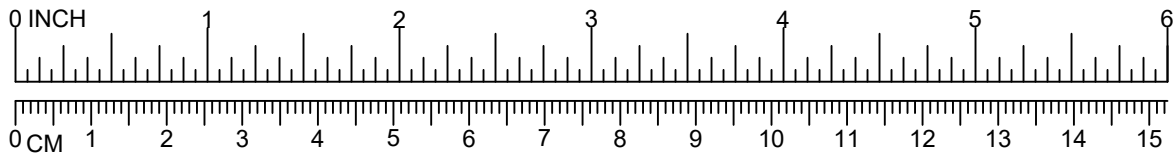

BT530 PLAYPOD MAZE CURVED

NOTE: REFER TO THE INSTALLATION PROLOG FOR TYPICAL THREADED INSERT AND EAGLE FASTNER INSTALLATION.

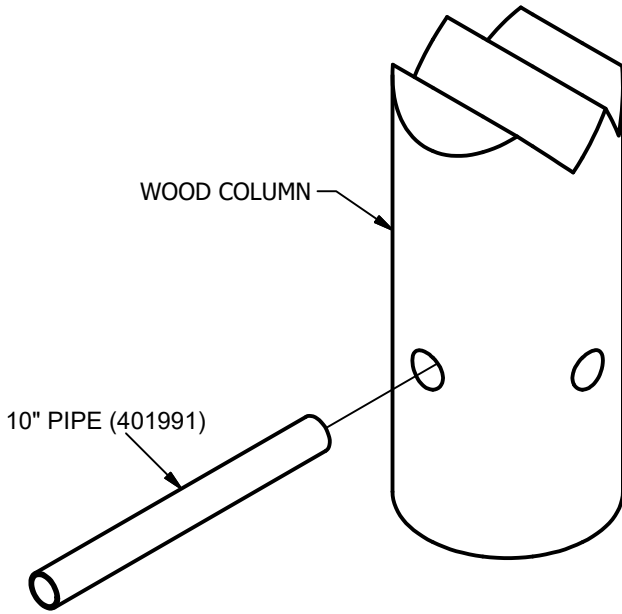

039

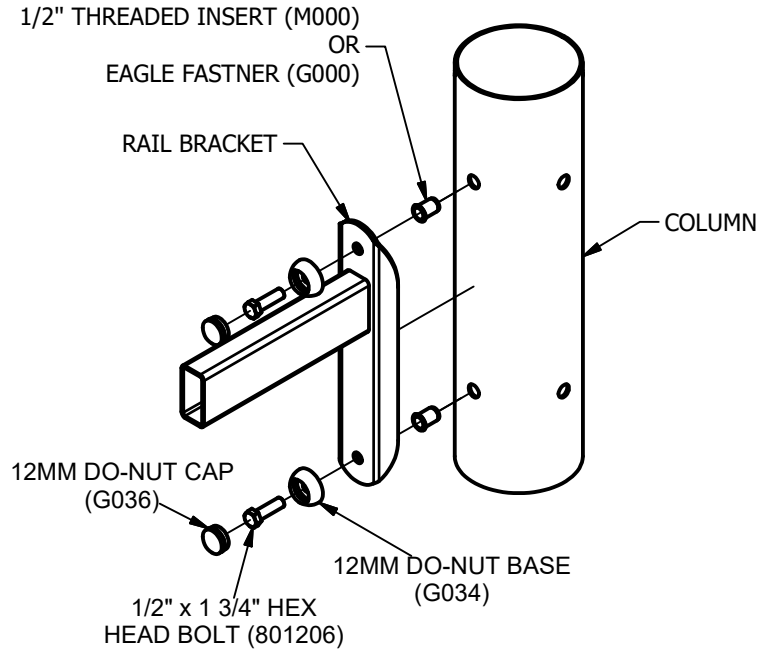

188

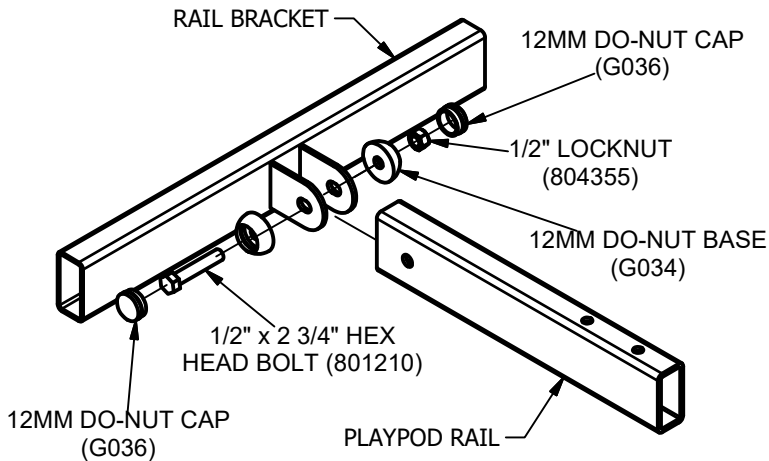

189