

MEC-035 AIRPLANE PANEL (Recycled) EC-035 AIRPLANE PANEL (Wood)

Parts List			
DESCRIPTION	MEC-035	EC-035	PART NUMBER
AIRPLANE PANEL	1	1	402569
BIGWHEEL w/SOUND & SHAFT ASSEMBLY	1	1	402796
RECYCLED UPRIGHT	2	0	404242
WOOD UPRIGHT	0	2	404247
HARDWARE COMPLETE	1	1	404289
3/8" x 1 1/2" HEX HEAD BOLT	3	3	801005*
3/8" x 5" HEX HEAD BOLT	4	4	801019*
3/8" LOCK NUT	7	7	804353*
3/8" INTERNAL TOOTH LOCKWASHER	8	8	817200*
ANCHOR ROD 3/8" X 6" ROUND BAR PLAIN	2	2	402121*
DO-NUT BASE 10MM	8	8	G030*
DO-NUT CAP 10MM	8	8	G032*

*Unless Otherwise Specified, All Units of Measure are Each
Items listed below Hardware Complete line are included with Hardware Complete Number*

Warning: During Installation, Hardware And Small Parts Are Choking Hazards For Young Children. Store Unused Parts Appropriately Until Assembly Is Completed. Once Assembly Is Completed, Remove Any Unused Parts From The Play Environment And Dispose/Save Them In A Secure Location. Any bolt end protruding more than two full threads beyond the face of the nut causes risk of clothing entanglement. Promptly cut-off flush, file smooth, and treat to prevent corrosion.

**Note: Peen Tee-Nuts and Flatwashers to match radius of pipe after assembly is complete.
Note: Loctite (supplied by others) should be used on any non-patch hardware.**

INSTALLATION INSTRUCTIONS:

1. Dig footing holes as shown in Elevation and Plan Views.
2. Locate Uprights and attach Airplane Panel using 3/8" x 5" Hex Head Bolt , 3/8" Internal Tooth Lock Washer, 3/8" Lock Nut, Do-Nut Base 10mm and Do-Nut Cap 10mm as shown in Detail 101. See Plan View for orientation.
3. Attach Bigwheel w/Sound & Shaft Assembly to Airplane Panel using 3/8" x 1 1/2" Hex Head Bolt and 3/8" Lock Nut and Set Screw. See Detail 095. See Finished Assembly for location.
4. Insert Anchor Rods through the bottom hole of the Uprights.
5. Plumb and level the entire assembly and tighten all fasteners.
6. After entire unit is assembled, pour concrete footings within 4" to the top and taper away from post for water drainage. Allow to cure at least 48 hours before use. Temporary bracing may be required until concrete cures.
7. When the structure is finished and satisfactory, eliminate sharp points and sharp edges (burring) on installed hardware like bolts, nuts etc. Install resilient surfacing material within the use zone of play structure in accordance with ASTM specifications F1292 appropriate for the fall height of each structure. Refer to the safety guidelines.

MEC-035 AIRPLANE PANEL (Recycled) EC-035 AIRPLANE PANEL (Wood)

MAINTENANCE PROCEDURE:

Periodically check hardware for tightness, and tighten as necessary. Always check all parts for breakage or wear, and immediately put equipment out of service until any faulty parts found are repaired or replaced. Also Check all metal parts for rust, paint loss and touch-up if necessary with paint. Check for welded areas and verify integrity. Check periodically resilient surfacing for appropriate depth and remove extraneous materials that could cause injury, infection, or disease. Maintain detailed installation, inspection, maintenance, and repair records for each public-use playground equipment.

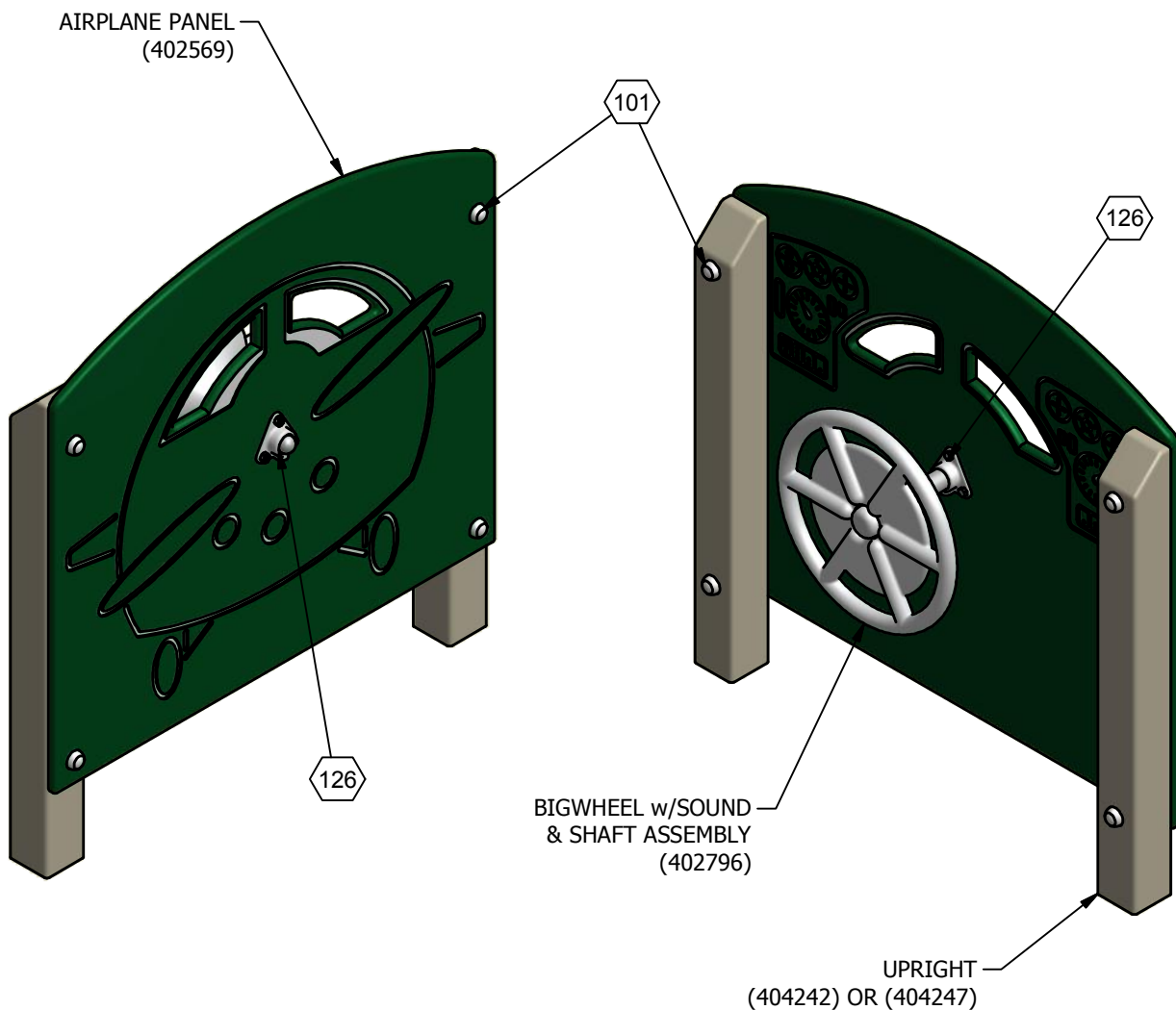

FINISHED ASSEMBLY

MEC-035 AIRPLANE PANEL (Recycled)
EC-035 AIRPLANE PANEL (Wood)

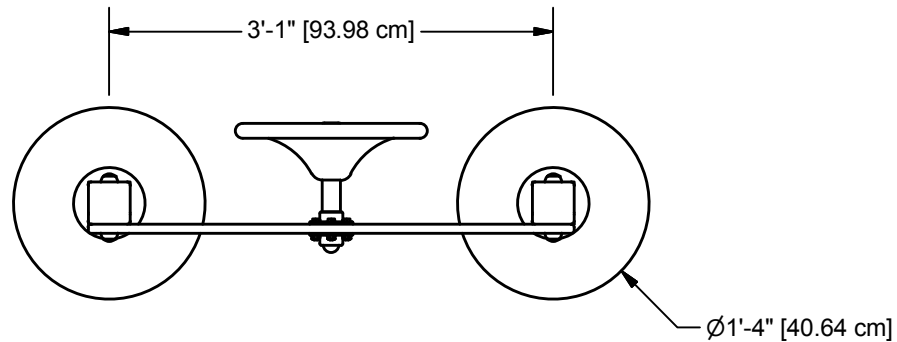

PLAN VIEW

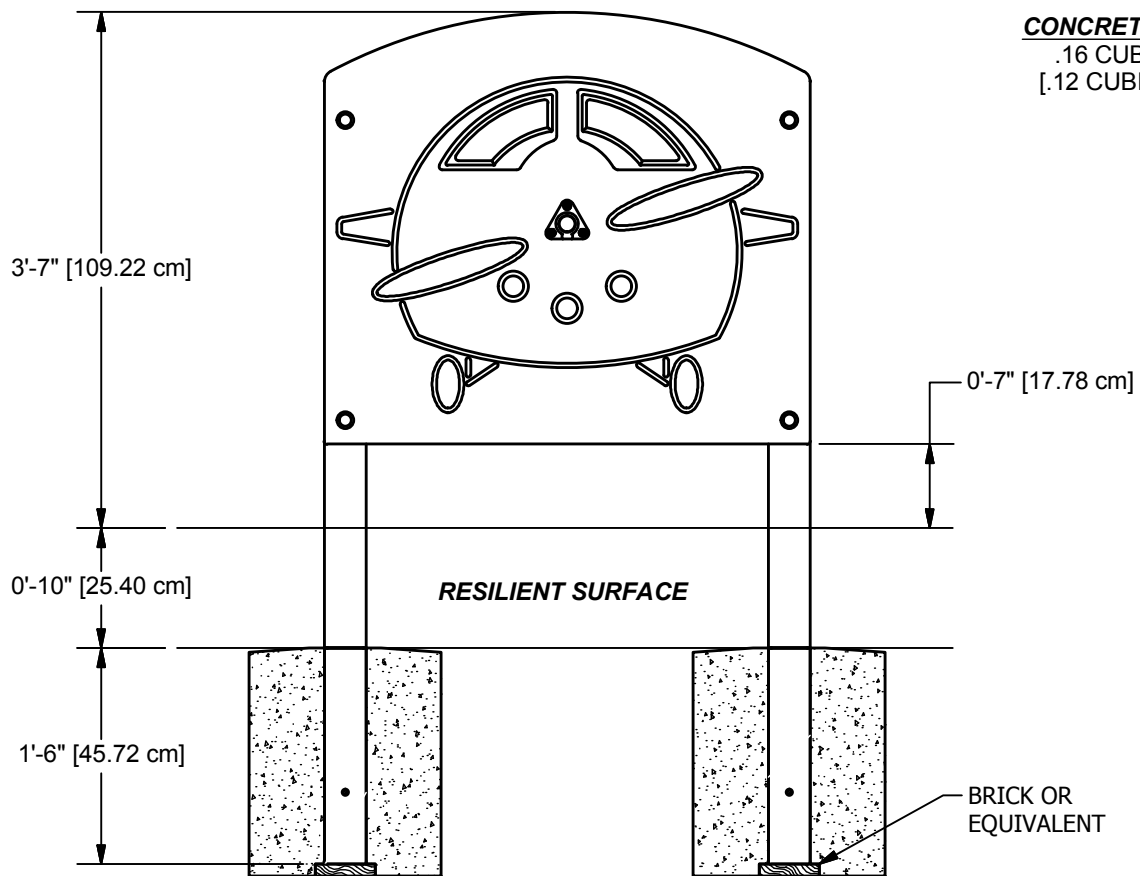

CONCRETE REQUIRED
 .16 CUBIC YARDS
 [.12 CUBIC METERS]

ELEVATION VIEW

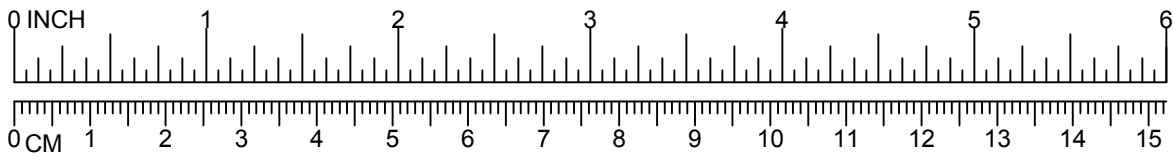

MEC-035 AIRPLANE PANEL (Recycled) EC-035 AIRPLANE PANEL (Wood)

