

## MEC-130 SYNCHRO JR.

Parts List			
ITEM	DESCRIPTION	QTY	PART NUMBER
1	CENTER POLE	1	2435
2	PLAYPOD W/1.38" HOLE	1	G441
3	48" FOOTING PIPE	1	G433GS
4	HUB/SPINDLE ASSY	1	404655
5	FINIAL 1	2	401585
	HARDWARE COMPLETE	1	404659
6	PLAYPOD TO HUB ADAPTER	1	402139
7	FINIAL SPACER 1	1	401588
	ANCHOR ROD	1	402121
	1/2" LOCKWASHER	3	817342
	1/2" x 1 1/4" B.H.C.S.	3	811062
	3/8" x 2" FLAT HEAD SOCKET CAP SCREW	1	811444
	3/8" x 1 1/2" FLAT HEAD SOCKET CAP SCREW	5	811442
	5/8" FLAT WASHER	1	817468
	BOLT, HEX 5/8-11 x 1 GRD 2 PLTD	1	801301
	3/8" FLAT WASHER	2	817410
	3/8" x 3/4" B.H.C.S.	2	811052
	3/8" COUPLER NUT	1	804811
	#8 x 3/4" WOOD SCREW	4	815517
	LABEL PACKAGE, 2-5 YEARS	1	E402E

*Unless Otherwise Specified, All Units of Measure are Each*

*Items listed below Hardware Complete line are included with Hardware Complete Number*

**Warning: During Installation, Hardware And Small Parts Are Choking Hazards For Young Children. Store Unused Parts Appropriately Until Assembly Is Completed. Once Assembly Is Completed, Remove Any Unused Parts From The Play Environment And Dispose/Save Them In A Secure Location. Any bolt end protruding more than two full threads beyond the face of the nut causes risk of clothing entanglement.**

**Promptly cut-off flush, file smooth, and treat to prevent corrosion.**

**Note: Peen Tee-Nuts and Flatwashers to match radius of pipe after assembly is complete.**

**Note: Loctite (supplied by others) should be used on any non-patch hardware.**

### **INSTALLATION INSTRUCTIONS:**

1. Dig footing holes as shown in Elevation and Plan Views.
2. Attach Finials and Finial Spacer to top of Center Pole Assembly using 3/8" x 3/4" B.H.C.S., 3/8" Flatwashers, #8 x 3/4" Wood Screws, and 3/8" Coupler Nut. See Detail A.
2. Attach Playpod to Center Pole using 3/8" x 1 1/2" Flat Head Cap Screws, 5/8" x 1" Hex Bolt, 5/8" Flatwasher and Hub Adapter. See Detail B.
3. Attach Hub/Spindle Assembly to Center Pole Assembly using 3/8" x 1 1/4" B.H.C.S. See Detail C.
6. Insert Anchor Rod into Footing Pipe. Place footing Pipe into footing hole. Confirm that the Footing Pipe is plumb before filling hole with concrete. Allow Concrete to cure at least 48 hours before use. Temporary bracing may be required until concrete cures.
7. Attach Synchro Spinner Assembly to Footing Pipe using 1/2" x 1 1/4" B.H.C.S. AND 1/2" Lockwasher. See Detail D.
8. Attach Warning Label and Age Appropriate Label on the outside of Footing Pipe as high as possible.  
*Note: Areas must be clean and dry before attaching Labels.*

## MEC-130 SYNCHRO JR.

### **MAINTENANCE PROCEDURE:**

Periodically check hardware for tightness, and tighten as necessary. Always check all parts for breakage or wear, and immediately put equipment out of service until any faulty parts found are repaired or replaced. Also Check all metal parts for rust, paint loss and touch-up if necessary with paint. Check for welded areas and verify integrity. Check periodically resilient surfacing for appropriate depth and remove extraneous materials that could cause injury, infection, or disease. Maintain detailed installation, inspection, maintenance, and repair records for each public-use playground equipment.

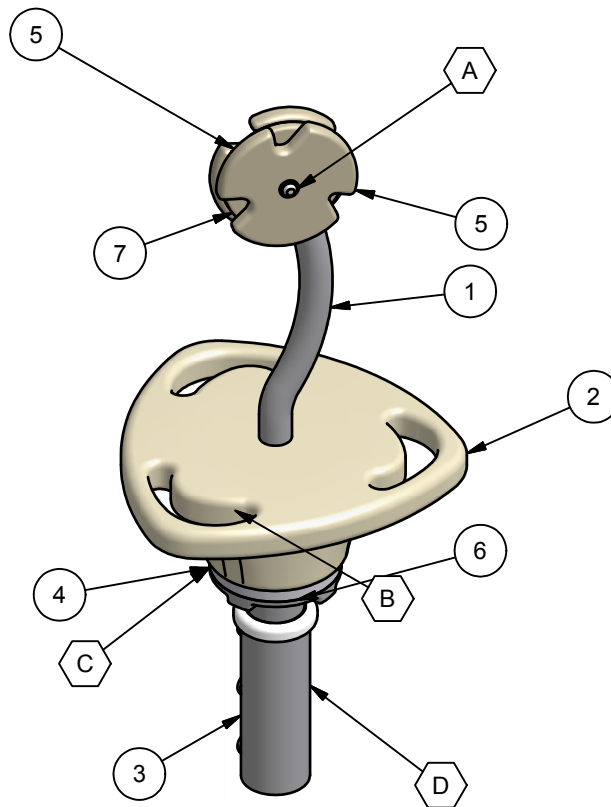

**FINISHED ASSEMBLY**

MEC-130 SYNCHRO JR.

**CONCRETE REQUIRED**

.30 CUBIC YARDS  
.23 [CUBIC METERS]

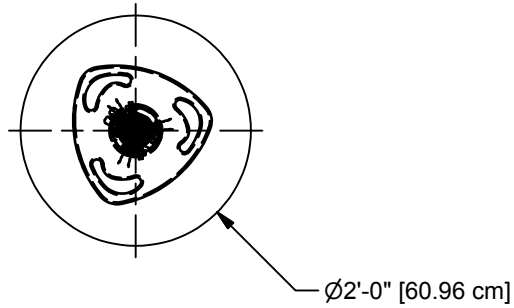

**PLAN VIEW**

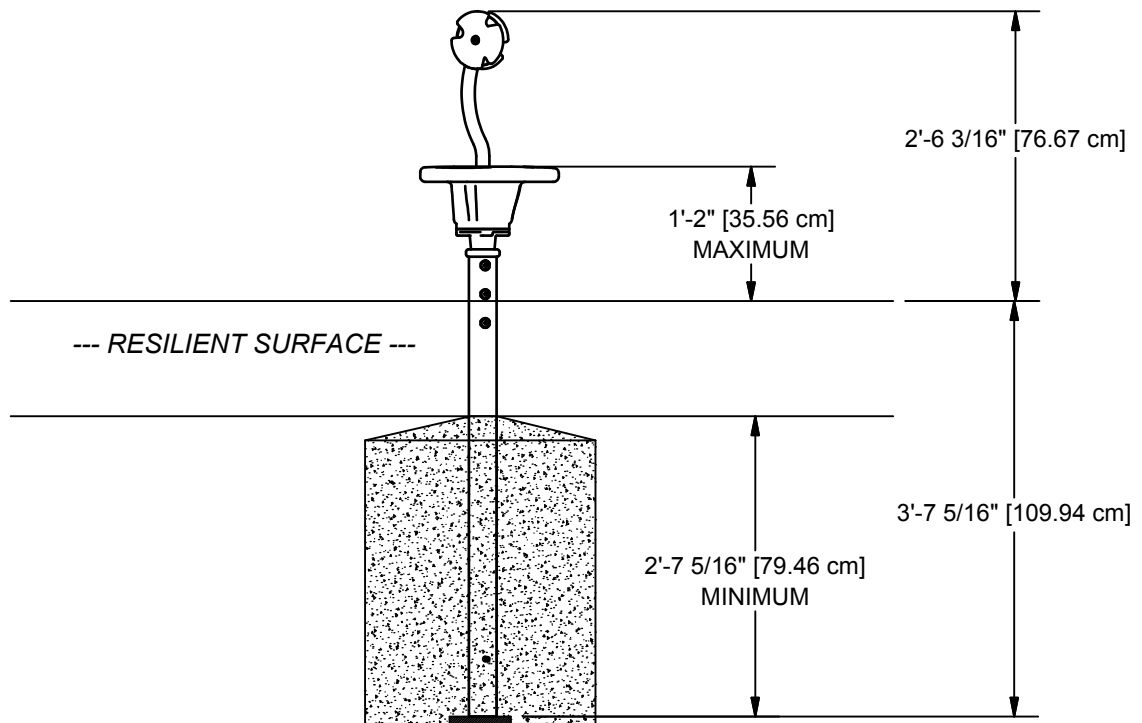

**ELEVATION VIEW**

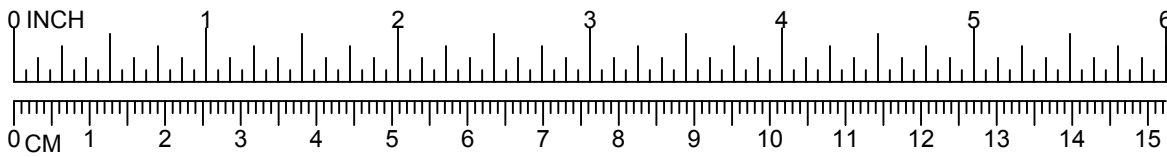

# MEC-130 SYNCHRO JR.

