

Model Numbers:  
 TOT46-B-04-000 - Advantage Coating  
 TOT46-D-04-000 - Industry Standard Coating

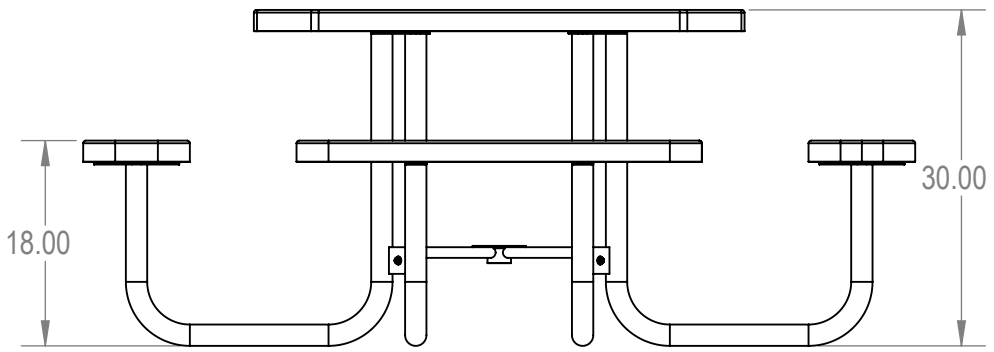
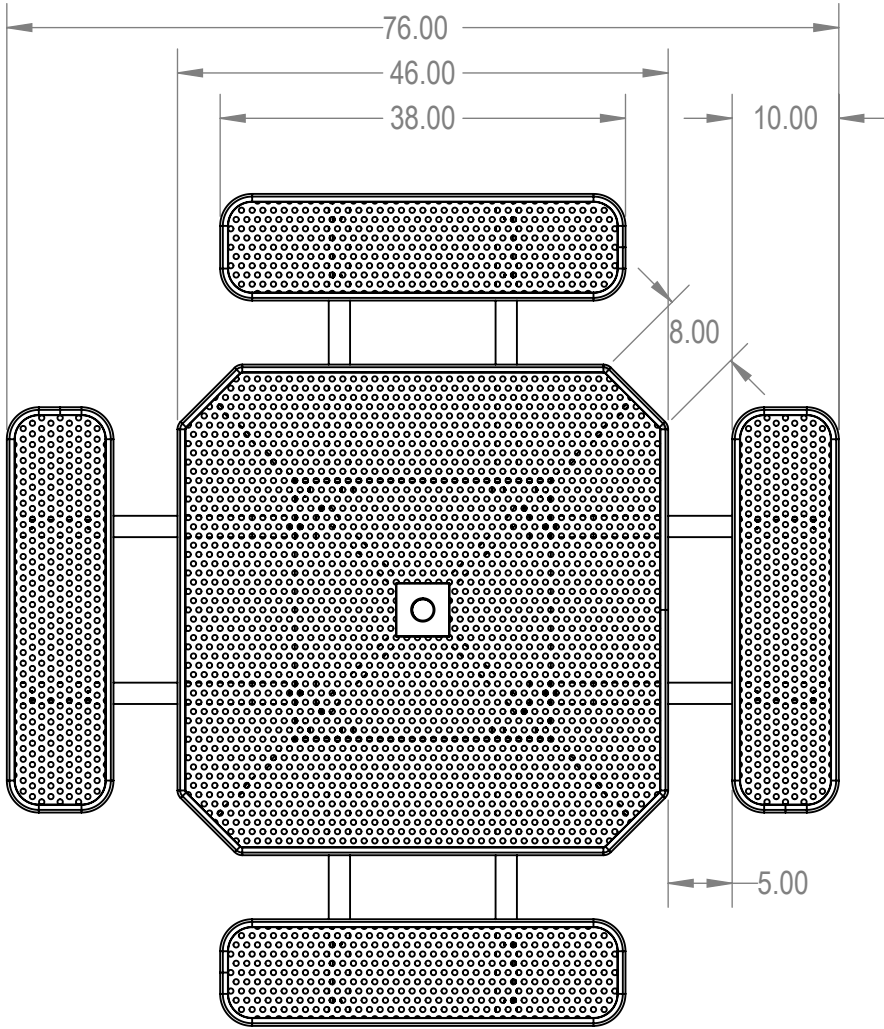

Mfg. by Advantage Panels & Fence, Inc.

**MyTCoat**

Commercial Outdoor Furniture

[www.mytcoat.com](http://www.mytcoat.com)

**PROPRIETARY AND CONFIDENTIAL**  
 THE INFORMATION CONTAINED IN THIS DRAWING IS THE SOLE PROPERTY OF Advantage Panels & Fence, Inc. PO Box 1790 Whitney, TX. ANY REPRODUCTION IN PART OR AS A WHOLE WITHOUT THE WRITTEN PERMISSION OF Advantage Panels & Fence, Inc. PO Box 1790 Whitney, TX. IS PROHIBITED.

	NAME	DATE
DRAWN	GM	1/8/2016
SALES APPR.		
CLIENT APPR.		
MFG APPR.		
Q.A.		

Design By -  
**CADWorksPro**  
 Chicago, IL  
[www.cadworkspro.com](http://www.cadworkspro.com)

**AAdvantage Panels & Fence, Inc.**

TITLE:  
 46" Octagon Table - Portable

**Perforated Metal Version**

SIZE <b>A</b>	DWG. NO.	REV
WEIGHT:		SHEET 3 OF 3